

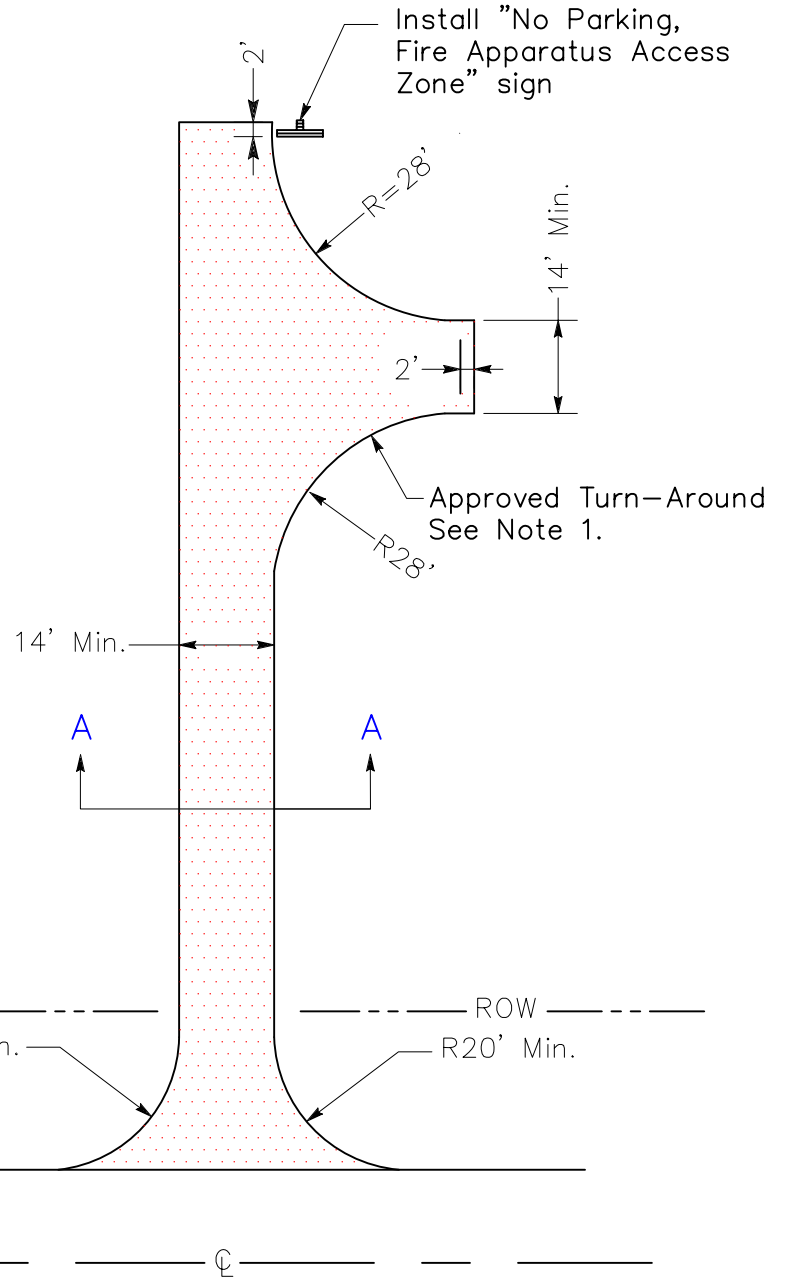

All driveways shall have a berm or a swale for drainage purposes.

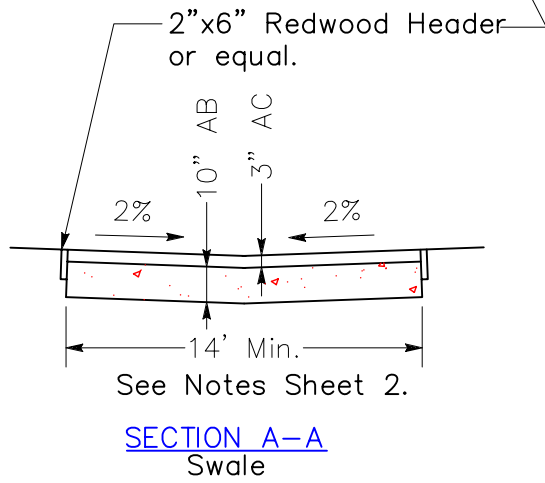
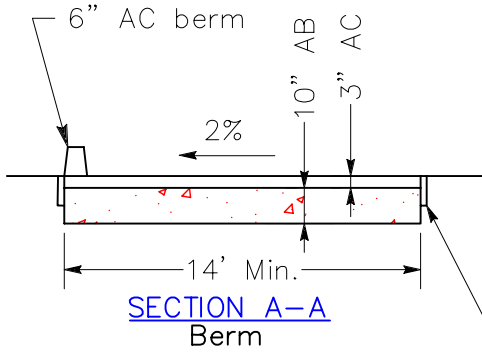

COORDINATE DESIGN WITH PUBLIC IMPROVEMENTS.

 Area to be paved with a minimum 3" AC and 10" AB to City of Concord Specifications.

See sheet 2 for notes.

Not to Scale

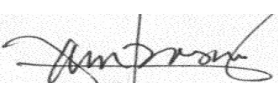

  
City Engineer  
01/16/07  
Date

▲			
▲			
▲			
NO	BY	DATE	REVISION

SHEET  
1 of 2

STANDARDS FOR  
PRIVATE  
STREET/DRIVEWAY

S-35

NOTES

1. No turnaround is required for one (1) lot if the length of the private drive does not exceed 150' as measured from the existing edge of pavement or face of curb of the fronting street.
2. If two (2) lots are to be served, pavement shall be a minimum of 16' wide with no parking allowed.
3. If three (3) or more lots are to be served, pavement shall be a minimum of 20' of unobstructed width with no parking, or 28' wide with parking on one (1) side, or 36' wide with parking on both sides.
4. Easement access width shall be at least 1' wider than the required minimum pavement width.
5. Adequate storm drain facilities will be required to provide drainage. All construction within public right-of-way shall be done in accordance with the latest City of Concord Standard Plans and Specifications and Concord Municipal Code.

Not to Scale



*[Signature]*  
 City Engineer  
 01/16/07  
 Date

NO	BY	DATE	REVISION
△			
△			
△			

SHEET  
 2 of 2

STANDARDS FOR  
 PRIVATE  
 STREET/DRIVEWAY

S-35